

HOPE'S®



HOPE'S®

Congratulations on discovering Hope's – the source of the world's finest windows and doors for the world's finest luxury homes.

That's a bold statement. But I make it with a depth of personal knowledge that reinforces this truth and the complete confidence that you'll agree once you spend time getting to know Hope's incomparable product offerings.

Explore Hope's in detail and you will quickly discover unmatched durability and longevity, a quality of refined elegance impossible to achieve with other materials, and a new level of freedom to design and build custom windows and doors for truly extraordinary homes.

My hope is this overview helps you begin this process of discovery, leading you to make the best possible decision for your luxury home – an investment in Hope's windows and doors.

On behalf of all of us at Hope's, we look forward to working with you on your next project with the shared goal of creating remarkable, efficient, and enduring residential architecture according to your vision.

Enjoy,



Randall P. Manitta
CEO/President
Hope's Windows, Inc.

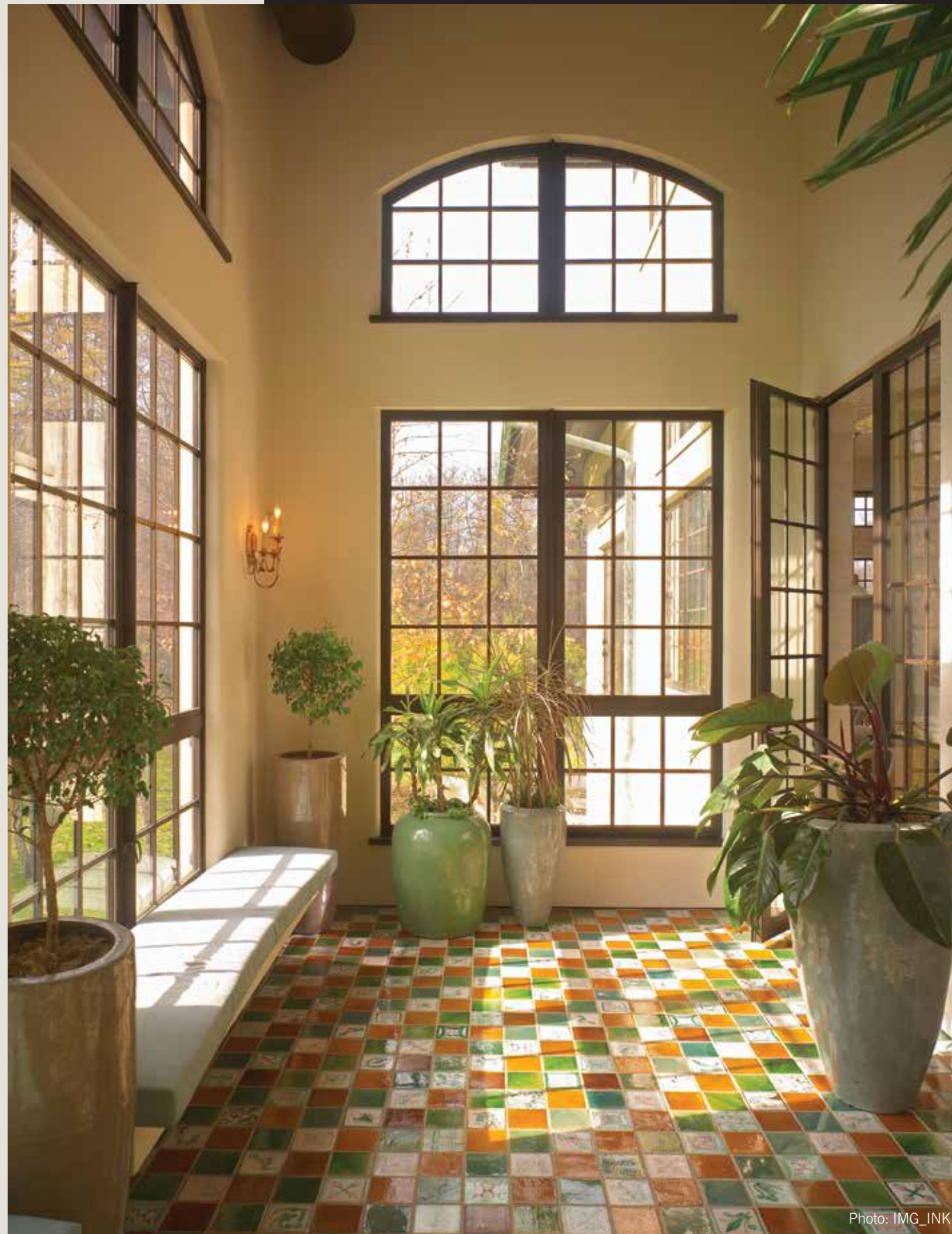

Photo: IMG_INK

CONTENTS

MATERIALS

- 3 The Genesis
- 4 Material Difference

DESIGN

- 5 Aesthetic
- 6 Customized Design
- 7 Styles and Finishes
- 8 Craftsmanship

PERFORMANCE

- 9 Proven Performance and Testing
- 10 Corrosive and Hurricane Resistance, Thermal Performance, Safety, and Security
- 11 The Ultimate in Life Cycle Value
- 12 Thermal Evolution™ Technology

DESIGN SUITES

- 13 Your Design Palette
- 14 Steel Product Series
- 15 Bronze Product Series

PORTFOLIO

- 16-23

PROFESSIONAL SERVICES

- 24 Services

THE GENESIS OF HOPE'S WINDOWS AND DOORS

The story of Hope's custom windows and doors starts with artisans that transform solid steel billet into a variety of slim, geometrically complex, and remarkably strong profiles. This transformation is achieved through hot-rolling, a process where steel is heated to be malleable, then formed through an array of precision tooling to its final geometry.

With these precision-made profiles, Hope's crafts the world's finest windows and doors. Experience unprecedented freedom of architectural expression.



Photos: Courtesy of Montanstahl

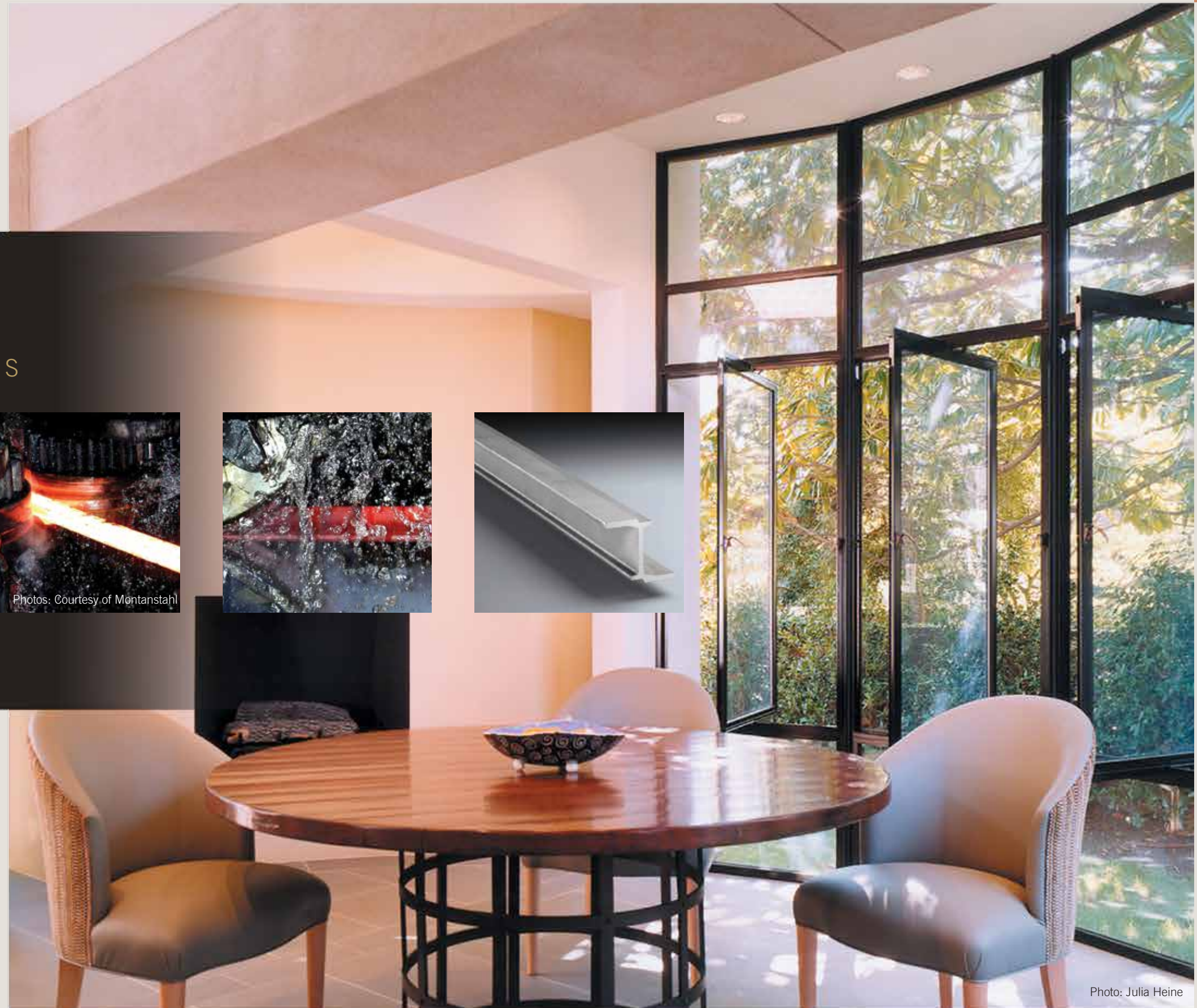

Photo: Julia Heine

THE MATERIAL DIFFERENCE

Hope's is committed to crafting windows and doors only from materials with proven ability to last for a century or longer, while providing timeless aesthetic appeal.

SOLID HOT-ROLLED STEEL

For more than 150 years, windows and doors have been crafted from solid hot-rolled steel. Many of our nation's historic mansions dating from the 1860s and earlier feature these handcrafted materials. Today, it is common for new homes to utilize wood or aluminum windows and doors, not because these materials are superior – they're simply less expensive.

What makes solid hot-rolled steel a superior material? For starters, it's three times stronger than aluminum and sixteen times stronger than wood. This strength allows Hope's to make windows and doors with the slimmest frames, the greatest amount of glass, and in virtually unlimited scale, shapes, and configurations.

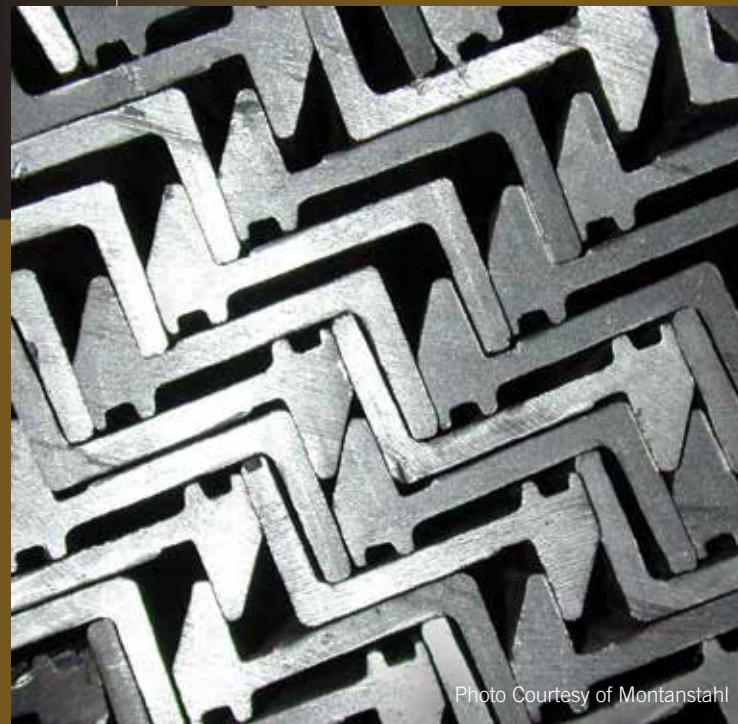
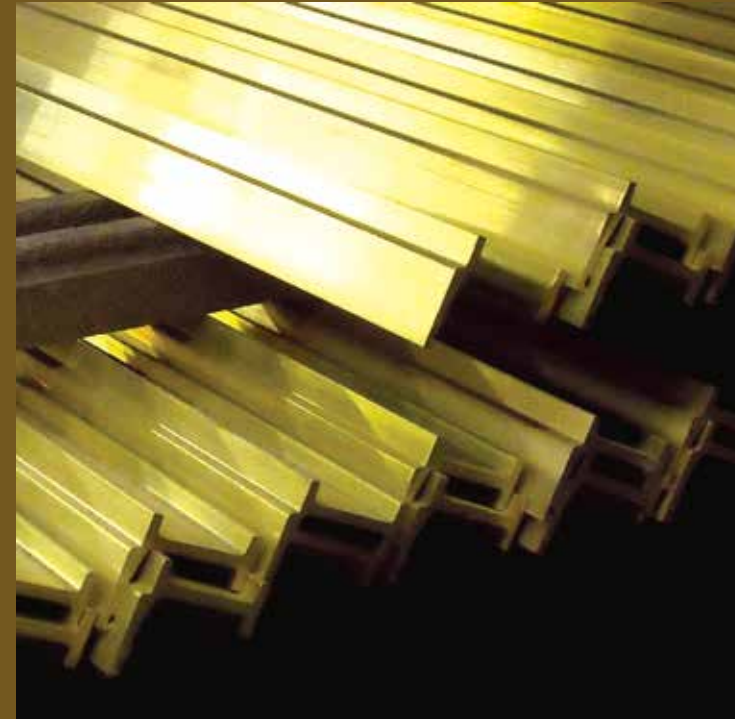

Photo Courtesy of Montanstahl



SOLID BRONZE

For centuries, bronze has been the material of choice for the most luxurious homes. Bronze is unmatched for its ultimate durability and timeless beauty. Solid bronze offers unprecedented resistance to corrosion, even in coastal environments.

CUSTOM FORMED STEEL OR BRONZE

To achieve certain performance or aesthetic requirements, Hope's also handcrafts windows and doors by transforming heavy gauge steel, stainless steel, or bronze into custom formed profiles.



GRACEFUL, SLENDER, ELEGANT, REFINED.

These words often describe the unique look of Hope's windows and doors. The narrow and graceful lines of Hope's windows and doors belie their formidable strength and ultimate durability. Hope's windows and doors are timeless in appearance and endure generations.

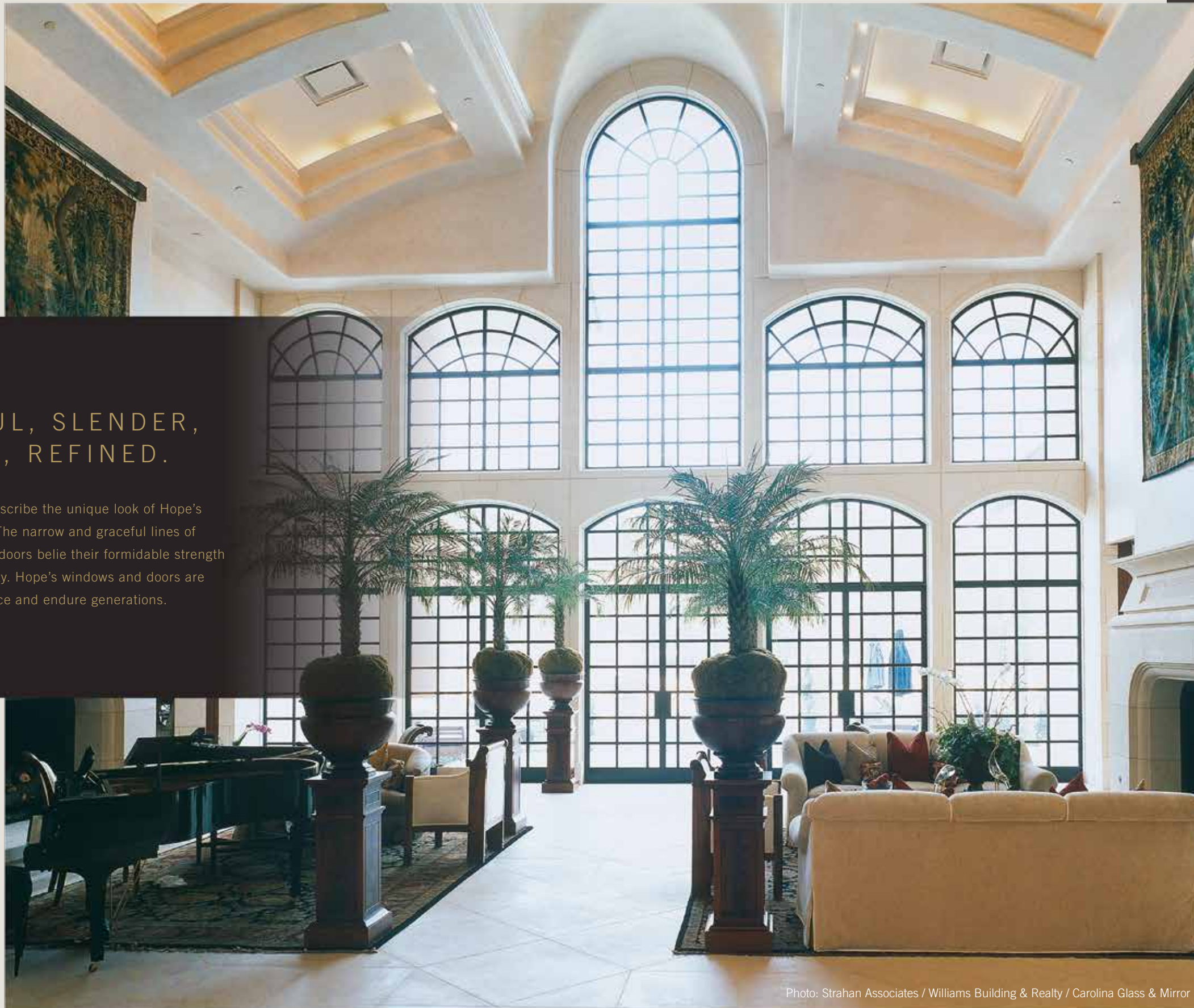
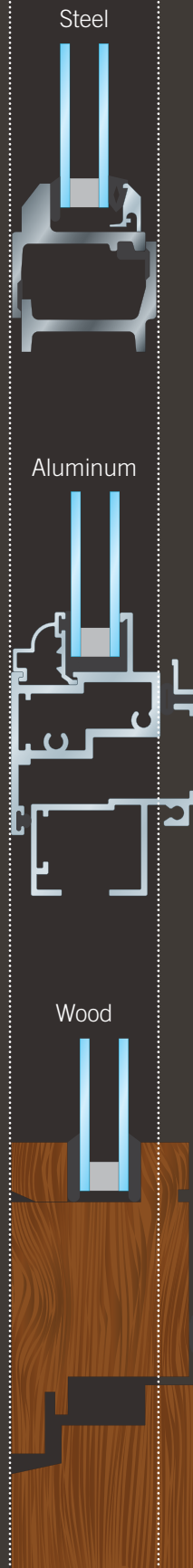

Photo: Strahan Associates / Williams Building & Realty / Carolina Glass & Mirror



Owing to the inherent strength of solid hot-rolled steel, the extremely narrow frame dimensions maximize glass area.

CUSTOM CHOICES AT EVERY PHASE OF DESIGN

Every Hope's window and door is custom designed by you – the architect, designer, and homeowner – to achieve your specific aesthetic and performance criteria. You choose the material – steel or bronze. You choose your frame profile, shape, size, and glass. You choose true divided lites or simulated divided lites. You choose fixed or operable windows, and you decide where and how your windows open and close. You choose the functionality of your doors – swing-in, swing-out, lift-slide, or slide-fold. You choose your desired hardware – hinges, locks, handles, kick plates, and more – to ensure the longest-lasting and smoothest operation.

HELPFUL AND COMPREHENSIVE DESIGN ASSISTANCE

Hope's helps guide you along the way to ensure your vision is achieved. Hope's has earned a reputation for continuously achieving new possibilities in window and door design. Offering more interesting forms on the grandest scales and with more dynamic functionality, no design is too ambitious for Hope's.



Photo: Francis Dzikowski Photography



Photo: IMG_INK



Photo: Patrick W. Price

ANY STYLE IMAGINABLE

Whether new construction, remodeling, or historic preservation, architects incorporate Hope's windows, skylights, and doors into every variety of architectural style from grand renaissance and gothic revival estates to imaginative avant-garde and postmodern luxury homes.

BEAUTIFUL FINISHES

To achieve the longest life cycle potential for Hope's steel windows and doors, Hope's provides the world's most advanced finishing system. Developed in cooperation with top U.S. metallurgists and architectural coatings suppliers, Hope's finishing system is engineered to ensure that windows and doors remain pristine and free from corrosion decade after decade, even in the harshest of environments.

Hope's finishing process is the most comprehensive coating system available. For the top coat, there are unlimited color choices, including metallics and patinas. You can also work with Hope's to create a custom color to perfectly integrate with your design.



Photo: IMG_INK



Photo: IMG_INK



Photo: Carlos Domenech Miami, FL

ATTENTION TO YOUR EVERY DETAIL

Hope's custom crafts each and every window and door to the absolute highest standards of quality and excellence.

Hope's continuously invests in new high-tech manufacturing equipment, when and where technology can enhance quality and product performance.



SHAPING

Solid hot-rolled steel or solid bronze profiles are formed perfectly to specified shapes, including complex curves.

FUSION WELDING

Steel profiles are joined by fusion welding, a process that fuses the steel together, forming one continuous frame.

The slag that forms at welded joints is ground and sanded smooth until visually imperceptible. The window or door now appears to have been made from a single piece of solid steel or bronze.

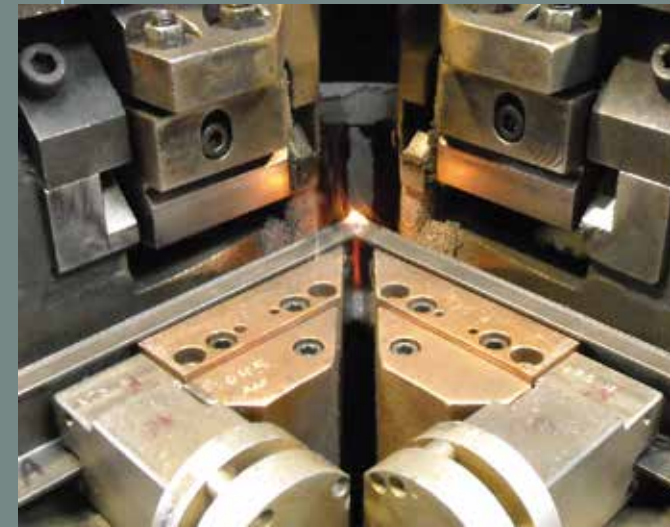

THERMAL EVOLUTION™

Windows and doors equipped with Thermal Evolution™ technology feature fiber-reinforced polymer (FRP) isolators. These isolators are precision machined to nest perfectly within Hope's traditional hot-rolled solid steel frame profiles where they are permanently bonded.



PERFECTION

Formed steel and bronze windows undergo rigorous fabrication procedures to achieve structural and visual perfection.

LASER

Hope's 5-axis laser precision cuts heavy gauge steel and bronze for complete design flexibility.

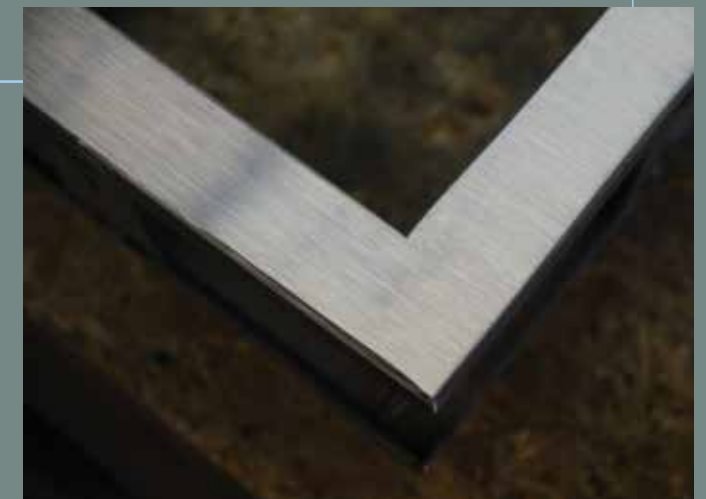

PROVEN PERFORMANCE YOU SHOULD EXPECT FROM CUSTOM CRAFTED WINDOWS AND DOORS

There are steel windows and doors on the market, and then there are Hope's custom crafted windows and doors that set the standard to meet and exceed the highest expectations of the owner, architect, designer, and builder. Hope's provides peace of mind with products that are tested and proven to deliver protection solutions – from inclement weather, harsh/extreme environments, and even dangerous situations caused by man or Mother Nature. The product protects itself and your home.

THIRD-PARTY TESTING AND CERTIFICATION

Hope's prides itself on its long-standing commitment to testing and certification, subjecting its products to more third-party testing and certifications than any other steel window and door company. The process of exceeding both rigorous, independent testing and customer expectations begins with the engineering and design of Hope's products – expertise derived from more than 100 years of experience. Hope's transparently provides detailed information about its testing results and certifications, including hurricane-impact resistance, air infiltration, water penetration, structural integrity, forced entry resistance, thermal performance, paint finish performance, fire resistance, bullet resistance, and bomb-blast protection. For detailed testing results from industry organizations such as ASTM, NFRC, and the Florida Building Code, among others, contact Hope's directly.



PROTECTION FROM CORROSIVE ENVIRONMENTS

Hope's protective coating system provides incomparable protection against corrosion and abrasion. Hope's comprehensive finishing system protects your investment whether your home is inland or ocean-front. Hope's finishing processes exceed the most rigorous testing standards and are carefully scrutinized to ensure products will perform, both aesthetically and functionally, for decades to come.

THERMAL PERFORMANCE AND ENERGY EFFICIENCY

The intrinsic properties of Hope's solid bronze and solid hot-rolled steel windows and doors provide optimal thermal performance as substantiated by third-party testing and NFRC certifications. With pioneering innovation, Hope's Thermal Evolution™ technology provides exceptional thermal performance and condensation resistance. The patented Thermal Evolution technology is third-party tested and NFRC certified.

HURRICANE AND IMPACT RESISTANT WINDOWS AND DOORS

Designed and tested to protect against the most brutal storms and flying debris, Hope's impact-rated hurricane windows and doors eliminate the hassle and added cost of hurricane shutters. Hope's offers the industry's largest selection of fully tested and certified windows and doors for use within hurricane and impact zones – including lift-slide and slide-fold door systems. Available in solid hot-rolled steel or bronze, Hope's custom crafted windows and doors provide timeless aesthetics, enhanced views, and passive storm protection.

ULTIMATE SECURITY

Safety and security are of utmost concern to homeowners and to Hope's. At Hope's, these concerns are taken into consideration with every product. Rest assured that Hope's offers window and door solutions that are designed, tested, and manufactured to ensure ultimate security against forced entry, and for providing lifesaving protection against bullet, bomb blast, or fire events – giving your family peace of mind.



THE ULTIMATE IN LIFE CYCLE VALUE

Every Hope's custom crafted window and door is built to last several generations – a century or longer – with minimal maintenance. Compare this long life cycle to alternatives such as wood and aluminum, and it's clear that Hope's is the best long-term investment both environmentally and financially.



Photo: Strahan Associates / Williams Building & Realty / Carolina Glass & Mirror

Solid steel operable window with Thermal Evolution™ technology.
U.S. Patent No. 8484902



THERMAL EVOLUTION™ TECHNOLOGY

Hope's revolutionizes windows and doors again by innovating the world's first and only thermally broken solid hot-rolled steel window and door system. Thermal Evolution technology is the only thermal isolation system to mitigate thermal loss and improve condensation resistance while enhancing the proven structural integrity of solid hot-rolled steel windows and doors. Thermal Evolution technology can also be incorporated into bronze or custom formed systems for increased energy performance.

Solid steel fixed window with Thermal Evolution™ technology.

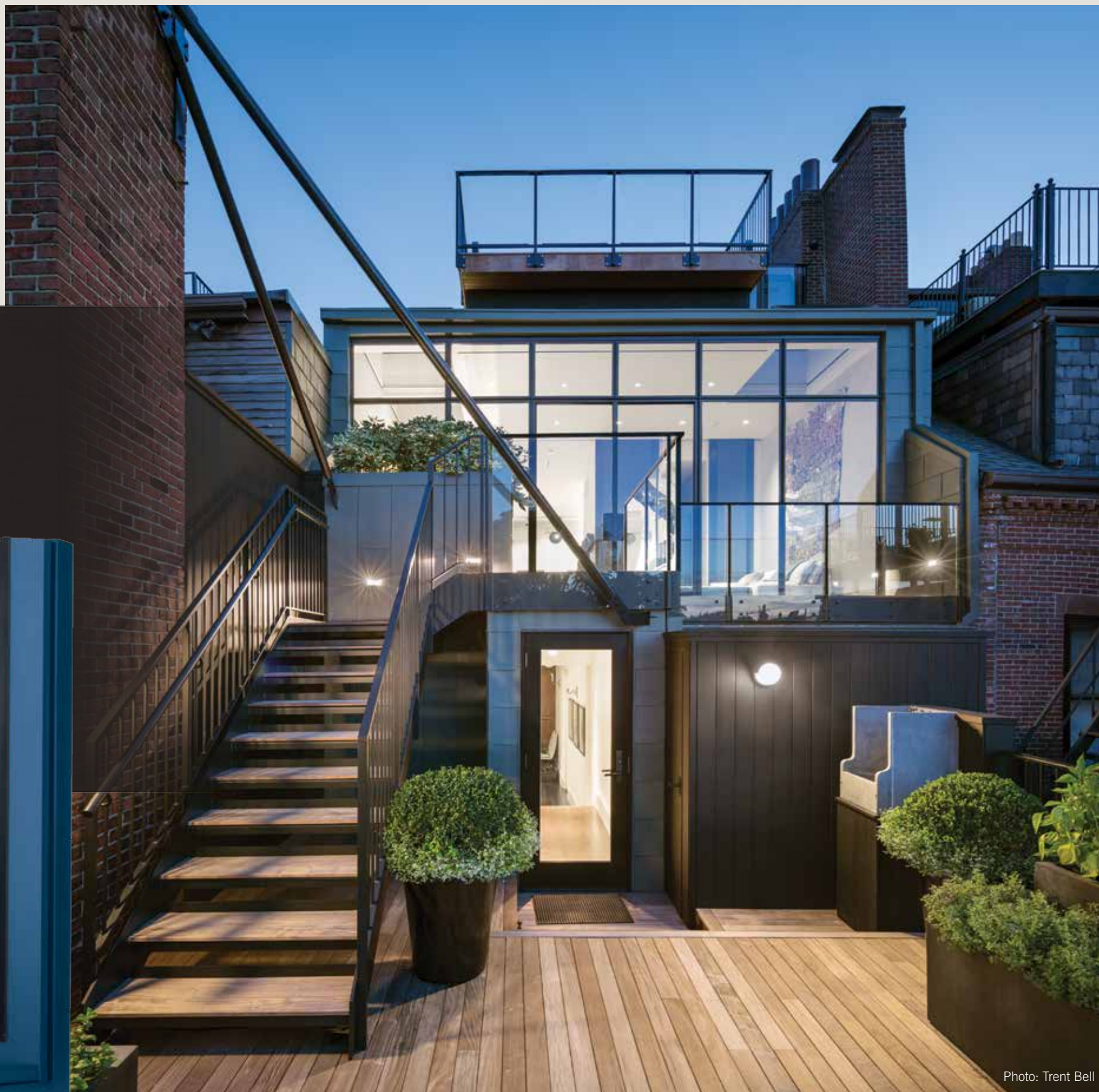
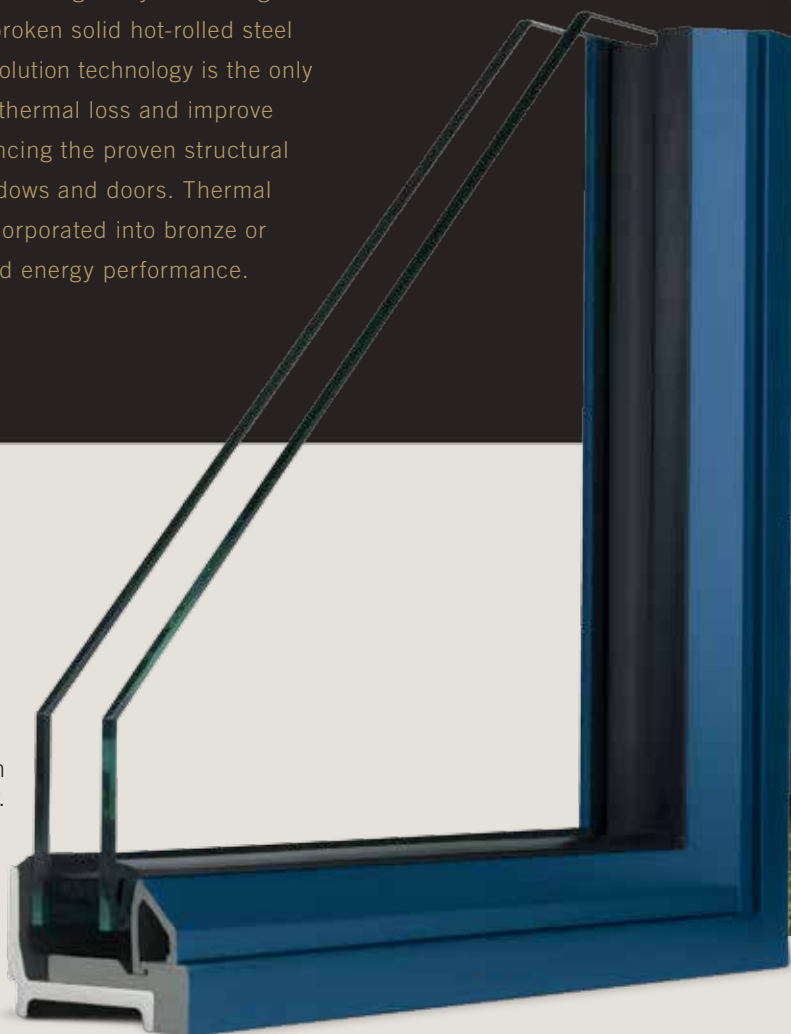

Photo: Trent Bell

YOUR DESIGN PALETTE

Designing a Hope's window or door begins with the selection of one of Hope's exclusive design suites – Jamestown175™ Series, Landmark175™ Series, University Series,™ One55™ Series, 5000 Series,™ or Empire Bronze.™ Each design suite consists of complementary framing and muntin profiles. A window or door may also be designed with a framing profile from one suite and a muntin profile from another. Again, the design is entirely yours.



Photo: Julia Heine

STEEL

JAMESTOWN175™ SERIES

Ideal for projects requiring oversize windows and doors with narrow sightlines. This series offers special operating types such as top hung or pivoting windows and is certified for use in special applications such as hurricane resistance.

LANDMARK175™ SERIES

Ideal for projects calling for classic solid steel windows and doors with slender sightlines. This series offers an even narrower sightline for operable windows and doors than our Jamestown175 Series.

UNIVERSITY SERIES™

Designed for projects requiring historic replication of exterior putty-glazed steel windows and doors. The unique profile and narrow sightlines are ideal for new construction as well as replacement projects.

ONE55™ SERIES

Designed for projects requiring replication of historic steel windows and doors with arrow-shaped profiles. This distinctive profile with its very narrow framing mimics the look of the earliest residential steel windows and historic industrial designs.

THERMAL EVOLUTION™

Ideal application for projects in extreme hot or cold climates. Hope's exclusive technology adds enhanced thermal resistance without compromising the structural integrity of the solid hot-rolled steel.

5000 SERIES™

Ideal for special operations – such as Offset Pivot, Lift-Slide, or Slide-Fold – these windows, doors, and skylights are custom formed from heavy gauge steel and complement our traditional hot-rolled steel products by providing the greatest latitude for design flexibility and hardware options.

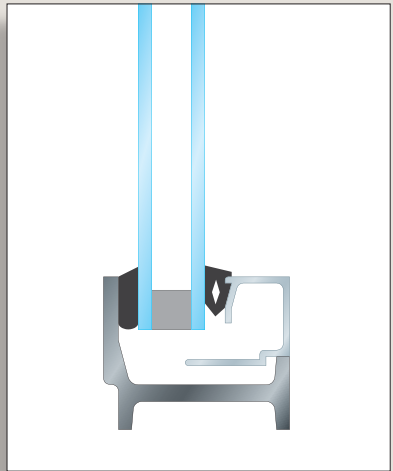

Fixed

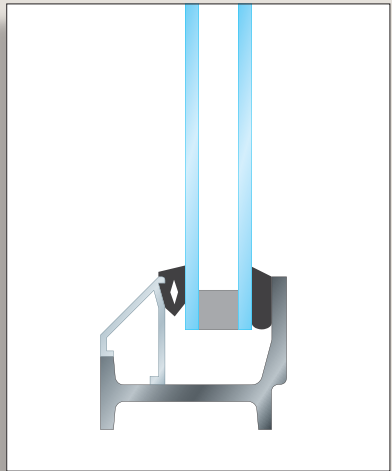

Fixed

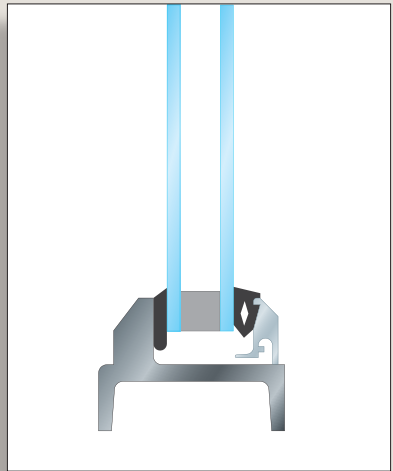

Fixed

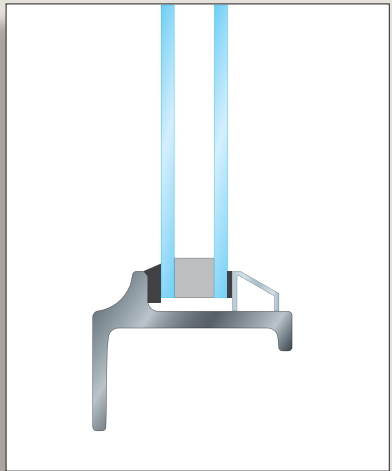

Fixed

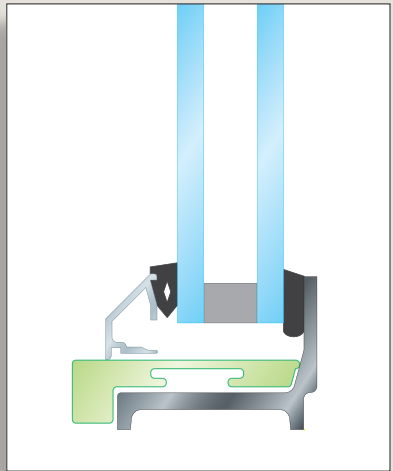

Fixed

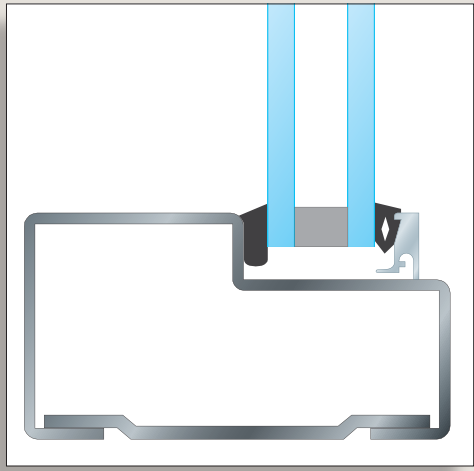

Fixed

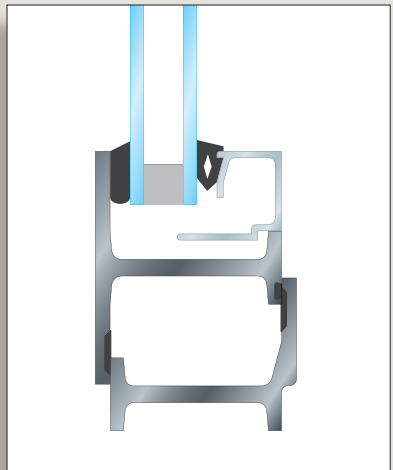

Operable

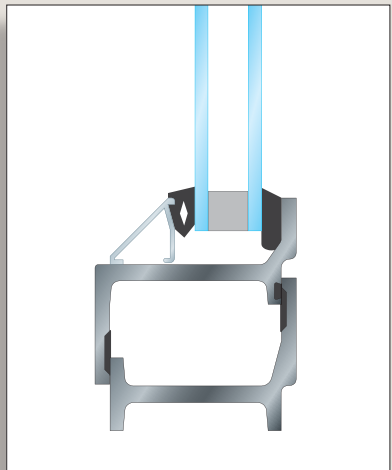

Operable

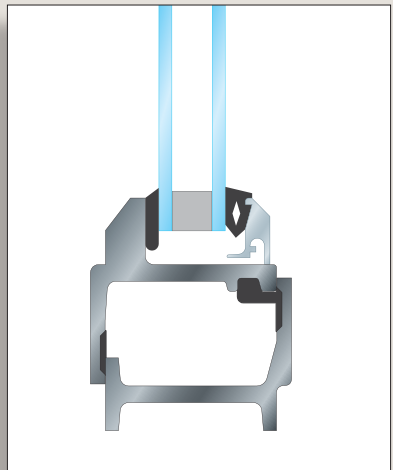

Operable

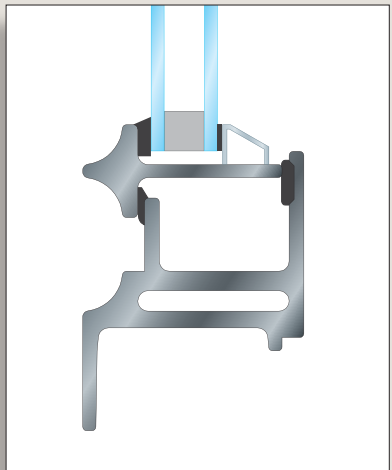

Operable

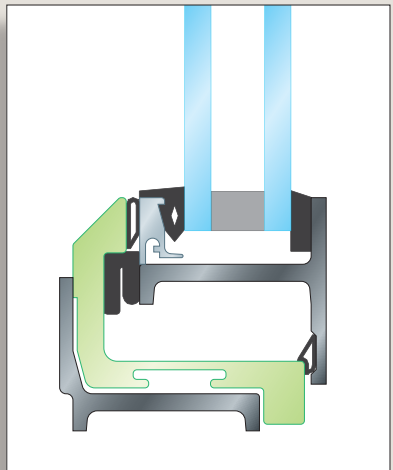

Operable

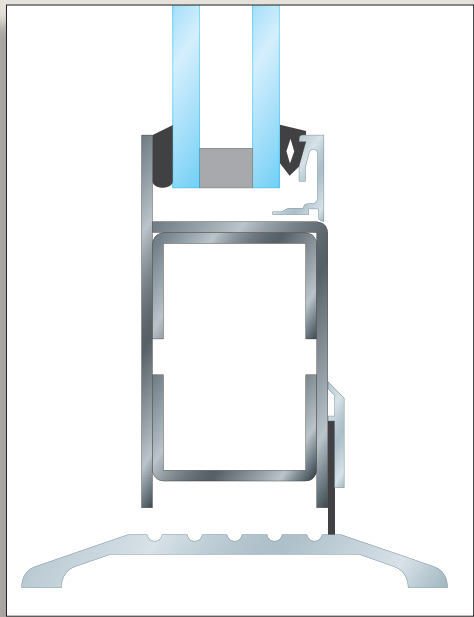

Door

Details not actual size

BRONZE

EMPIRE BRONZE™
JAMESTOWN175™
SERIES

Offers the ageless beauty of solid bronze with the elegant sightlines, durability, and meticulous manufacturing techniques synonymous with all Hope's products.

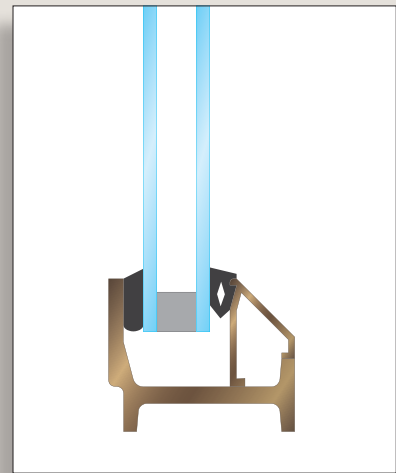

Fixed

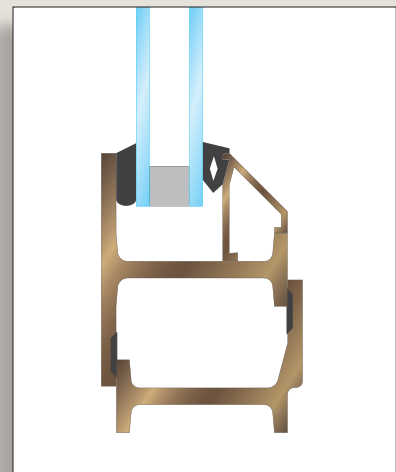

Operable

EMPIRE BRONZE™
5000 SERIES™

These windows, doors, and skylights are custom formed from heavy gauge bronze and complement our traditional hot-rolled bronze products by providing the greatest latitude for design flexibility and hardware options.

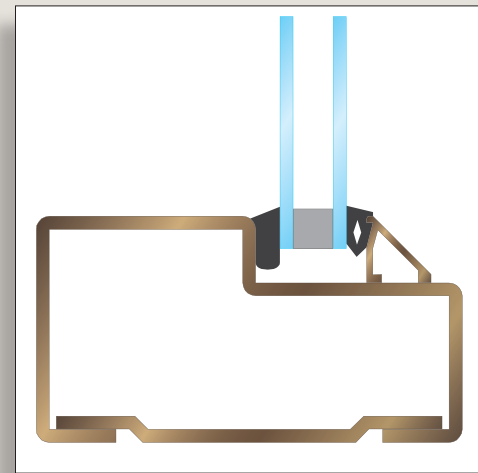

Fixed

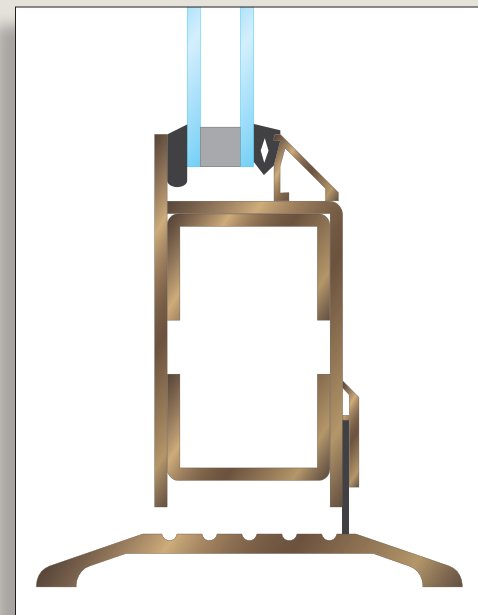

Door



Photo: Bruce Buck



Photo: IMG_INK



Photo: Carlos Domenech Miami, FL



Photo: IMG_INK



Photo: Tom Arban Photography, Inc.



Photo: Pete Albert



Photo: Julia Heine



PROFESSIONAL SERVICES

Hope's provides a complete menu of design and project services to assist with your project. These professional services include: design consultation; technical assistance; project-specific details and specifications; budgetary pricing; project management; custom submittal drawings; and engineering. To achieve your vision, contact Hope's today.



Photo: Tom Arban Photography, Inc.

HOPE'S®

Hope's Windows, Inc.
84 Hopkins Avenue
P.O. Box 580
Jamestown, NY 14702-0580
(716) 665-5124
(716) 665-3365 fax
HopesWindows.com



Photo: Glenn Hettinger